

COLLECTOR 37

USER MANUAL

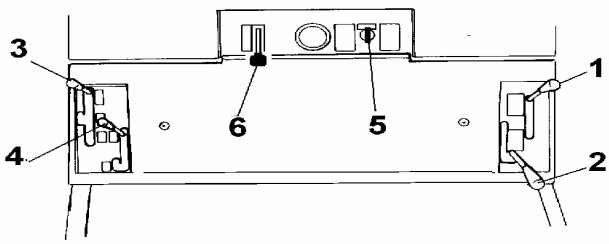

A



B

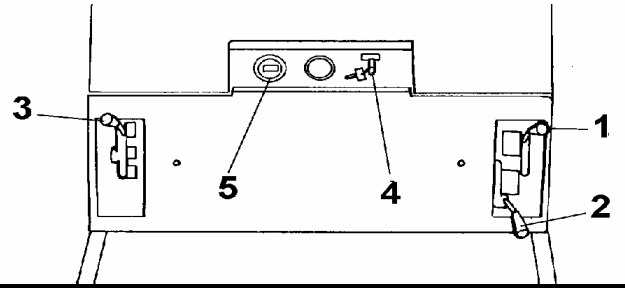

E

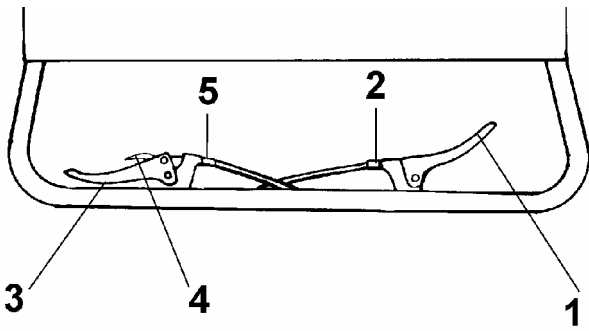

F

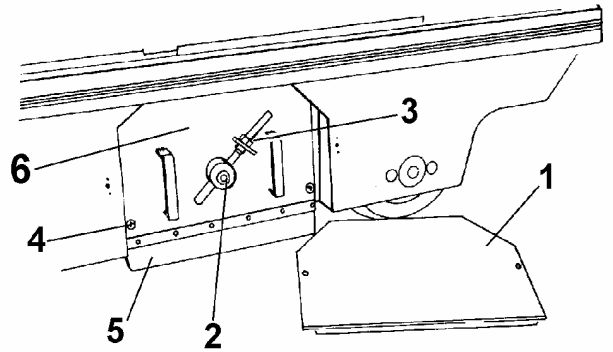

C

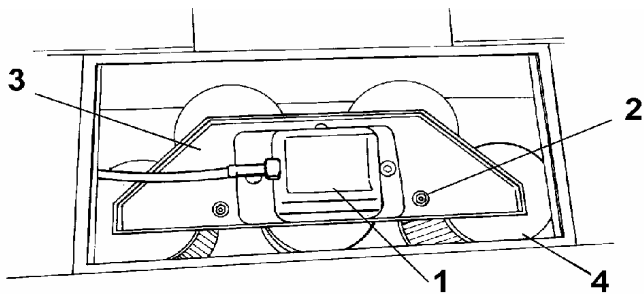

D

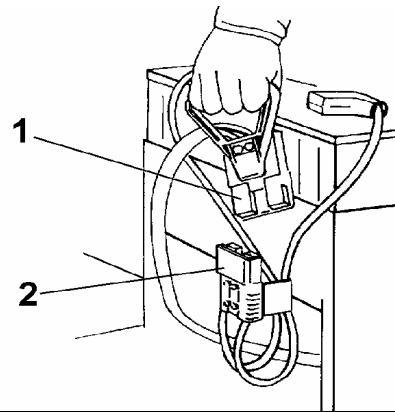

G

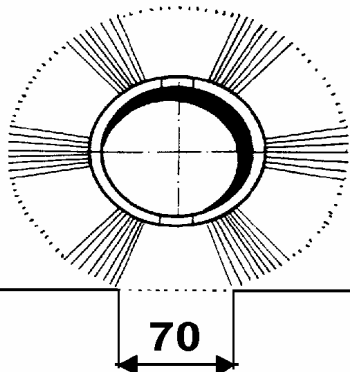

H

INTRODUCTION

“POWERBOSS,Inc.” leaders in the production of sweeping machines, are pleased to welcome you as an owner of the “Collector 37” sweeper machine. We are sure that its use will give you great satisfaction. We are also sure that while working with the Collector 37 you will have the opportunity to check the quality, solidness, and many applications for its use. The “Collector 37” sweeper machine is suitable for the cleaning of small and large surfaces, for private, industrial and public use. In this handbook are described and shown various operations of installation, control and maintenance, necessary to keep your Collector 37 in perfect working order. These are normal maintenance operations, which any operator can carry out with means normally available. In the case of work requiring special use or a check of the internal parts, You should contact your nearest POWERBOSS Service Center.

BEFORE USING THE MACHINE, CAREFULLY READ THIS MANUAL AND KEEP IT WITHIN EASY REACH FOR FURTHER REFERENCE.

The observance of the instructions given in this manual, and a cautious operator, are the best guarantee against accidents which may occur while working with the machine. The sweeping machines produced by POWERBOSS are designed according to the latest safety requirements, but they must be used following these instructions.

GENERAL NOTE

Our company aims towards a constant perfecting of its machines and reserves the right to carry out modifications and improvements whenever necessary without being to carry out the same operations on previously sold machines .

WARNING AND RECOMMENDATIONS

- IMPORTANT POINTS FOR THE SAFETY OF ALL THE PEOPLE INTERESTED IN THE USE OF THIS SWEEPER "COLLECTOR 37".
- THE SWEEPER HAS BEEN DESIGNED FOR THE CLEANING OF DRY FLOORS.
- DO NOT WORK IN THE PRESENCE OF TOXIC POWDERS.
- DO NOT WORK IN ENVIRONMENTS WHICH MAY BE UNDER RISK OF EXPLOSION.
- DO NOT COLLECT MATERIAL AND ALL THAT MAY LEAD TO FIRE (FOR EXAMPLE LIGHTED CIGARETTES)
- DO NOT COLLECT MATERIAL AND ALL THAT MAY LEAD TO FIRE (FOR EXAMPLE LIGHTED CIGARETTES)
- NEVER ALLOW ANYONE TO ENTER THE SWEEPER’S OPERATING AREA.
- NEVER LEAVE THE SWEEPER WITH THE ENGINE RUNNING ; TURN THE ENGINE OFF AND TAKE THE KEY AWAY.
- NEVER OPEN THE PROTECTIVE COVERS WHEN THE SWEEPER IS RUNNING.
- MAINTENANCE OPERATIONS SHOULD ONLY BE CARRIED OUT WITH THE ENGINE TURNED OFF.
- ONLY OPERATE THE SWEEPER FROM THE DRIVING SEAT.
- DO NOT ATTEMPT TO WORK ON SLOPES WHOSE GRADIENTS EXCEED THE VALUE SHOWN ON THE TABLE.
- DO NOT USE THE MACHINE FOR THE CLEANING OF OBJECTS.
- THE MAIN BRUSH MUST NOT SWEEP UP WIRES, ROPES, OR ANY OTHER LONG MATERIAL THAT MAY GET TANGLED WITH IT.
- DO NOT CARRY OUT ANY MODIFICATION TO THE MACHINE WITHOUT OUR PREVIOUS AUTHORISATION.
- THE SWEEPER HAS NOT BEEN APPROVED FOR USE ON THE PUBLIC HIGHWAY.

N.b. POWERBOSS,Inc. Declines all responsibility for any damage to person and/or property caused by a failure to observe the above rules or resulting from the inappropriate or incorrect use of the sweeper.

The sweeping machines manufactured by POWERBOSS,Inc. follow the CE directory and show the label:



DESCRIPTION OF PICTURES

PIC.1 COLLECTOR 37G “B&S” CONTROLS

- 1.FLAP LEVER.
- 2.MAIN BRUSH LEVER.
- 3.VACUUM CUT-OFF AND FILTER-SHAKER LEVER.
- 4.STRETCH-BELT LEVER.
- 5.KEYSWITCH.
- 6.ACCELERATOR LEVER.
- 7.SAFETY KEY.

PIC.2 COLLECTOR 37 “HONDA” CONTROLS

- 1.FLAP LEVER.
- 2.SIDE BRUSH LEVER.
- 3.VACUUM CUT-OFF LEVER.
- 4.STRETCH -BELT LEVER.
- 5.KEYSWITCH.
- 6.SAFETY KEY.

PIC.3 COLLECTOR 37E CONTROLS

- 1.FLAP LEVER.
- 2.SIDE BRUSH LEVER.
- 3.VACUUM CUT-OFF LEVER.
- 4.KEYSWITCH.
- 5.LOW BATTERY CHARGE WARNING LIGHT.
- 6.SAFETY KEY.

PIC.4 COMMON CONTROLS

- 1.TRACTION LEVER
- 2.TRACTION ADJUSTMENT SCREW.
- 3.PARKING AND SERVICE BRAKE LEVER.
- 4.PARKING BRAKE LEVER.
- 5.BRAKE SCREW.

PIC.5 MAIN BRUSH.

- 1.SIDE PANEL.
- 2.SCREW.
- 3.BRUSH SCREW.
- 4.LOCKING SCREWS.
- 5.SIDE RUBBER FLAP.
- 6.RUBBER FLAP HOLDER.

PIC.6 REPLACING THE FILTERS

- 1.ECCENTRIC SHAFT COVER.
- 2.LOCKING NUTS.
- 3.FILTER HOLDER.
- 4.FILTERS.

PIC.7 CONNECTORS AND BATTERY.

- 1.MOTOR CONNECTOR.
- 2.FIXED CONNECTOR.

PIC.8 MAIN BRUSH ADJUSTMENT.

COLLECTOR 37G BRIGGS & STRATTON MODEL

WARNING! For the maintenance and the correct use of the engine carefully read the original manual supplied by “BRIGGS & STRATTON” and strictly follow the instructions in it .

STARTING THE ENGINE

⇒Move the stretch-belt lever (n°4 PIC.1) to “B” position.

⇒Move the accelerator lever (n°6 PIC.1) to START position.

⇒Turn the key (n°5 PIC. 1) clockwise.

Do not use the electric start for more than 5 seconds each time. If the engine does not run, release the key and wait for at least 10 seconds before trying again.

Warning! It is important to make sure , before starting the engine , that lever n° 4 pic. 1 is on position b .This allows an easy and safe engine start as it is free from unnecessary load .

THIS EXCLUSIVE SYSTEM IS A “POWERBOSS,Inc.”

PATENT

⇒Let the engine run for at least a few seconds.

⇒Move the accelerator lever (n°6 PIC.1) to MAX position.

⇒Move the stretch-belt lever (n°4 PIC.1) to A position.

THE SWEEPER IS READY FOR WORKING

STOPPING THE ENGINE

⇒Move the accelerator lever (n°6 PIC.1) to MIN position.

⇒Turn the key (n°5 PIC.1) to “0” position.

⇒ or move the accelerator lever (n°6 PIC.1) to STOP position.

COLLECTOR 37 G HONDA MODEL

Warning! For the maintenance and the correct use of the engine carefully read the original manual supplied by "HONDA" and strictly follow the instructions in it.

STARTING THE ENGINE

- ⇒ Move the stretch-belt lever (n°4 PIC.2) to "B" position
- ⇒ Turn the fuel valve to the ON position. (consult the HONDA manual).
- ⇒ Move the choke to CLOSE position.
- ⇒ Move the throttle control lever slightly to the left.
- ⇒ Turn the key (n°5 PIC.2) clockwise.

Do not use the electric start for more than 5 seconds each time. If the engine does not run, release the key and wait for at least 10 seconds before trying again.

Warning! It is important to make sure, before starting the engine, that lever n° 4 pic. 1 is on position b. This allows an easy and safe engine start as it is free from unnecessary load.

THIS EXCLUSIVE SYSTEM IS A "POWERBOSS, Inc." PATENT.

- ⇒ Let the engine run for at least a few seconds.
- ⇒ Move the choke to ON position.
- ⇒ Move throttle control to maximum.
- ⇒ Move the stretch-belt lever (n°4 PIC.2) to A position.

THE SWEEPER IS READY FOR WORKING.

STOPPING THE ENGINE

- ⇒ Move the throttle control lever fully to the right.
- ⇒ Turn the key (n°5 PIC.2) to "0" position.
- ⇒ Turn the fuel valve to the OFF position.

COLLECTOR 37E

STARTING THE MOTOR

- ⇒ Turn the key (n°4 PIC. 3) to the 1 position.

STOPPING THE MOTOR

- ⇒ Turn the key (n°4 PIC.3) to the 0 position.

BATTERY CHARGE INDICATOR

⇒ It monitors the level of charge of the battery. While the green led is on, you can sweep. When the yellow led gets on, you must take care to go to have the battery charged. When the red led gets on, you must immediately switch off the machine, because the battery, if further discharged, can get irreversibly damaged its structure.

HOW TO CHARGE BATTERIES

- ⇒ Turn off the machine.
- ⇒ Disconnect the plug (n°1 pic.7) and connect the battery charger's plug.
- ⇒ Charge the batteries to a level not above 1/20th of their capacity.
- ⇒ Check level of electrolyte and top it up, if necessary, with distilled water.
- ⇒ When the batteries are charged, connect again the connector (n°1 pic.7) to the connector (n°2 pic.7).

WARNING !

- ⇒ Batteries must be charged in ventilated places.
- ⇒ The gas generated during charging operations may produce explosions when in presence of flames or sparks.
- ⇒ The battery acid must not come in contact with eyes, skin, clothes, painted or zinc coated surfaces.
- ⇒ Should this happen, wash off the acid with water.
- ⇒ Do not lean metallic objects over the batteries.
- ⇒ Remove all caps from the various battery cells before charging the battery.
- ⇒ Do not top up with sulphuric acid.

DANGER AND OBLIGATIONS SYMBOLS.

	DANGER SYMBOL. WARNING: very hot surfaces
	OBLIGATION SYMBOL. WARNING : Use adequate acoustic protection. In a number of working environments, sweepers might generate an acoustic danger which can be eliminated with adequate acoustic protection.

EMERGENCY CASES.

STRICTLY OBSERVE THE FOLLOWING INSTRUCTIONS :

- ⇒ In the event of fire, use only powder fire extinguishers.
- ⇒ In the event of unusual failures (engines or motor overheating, etc.) turn off immediately the machine.

HOW TO USE THE MACHINE

TRACTION

- ⇒ The mechanical traction is engaged by pulling the left lever (n°1 PIC.4) from the handle.
- Note : we recommend, when turning, that speed be decreased in order to gain better manoeuvrability.

SERVICE AND PARKING BRAKE

- ⇒ The service brake is activated by the brake lever (n°3 PIC.4).
- ⇒ The parking brake is activated by the brake lever (n°3 PIC.4).
- ⇒ To release the brake, completely pull the brake lever (n°3 PIC.4), pull the smaller lever (n°4 PIC.4) then release.

FLAP LEVER

- ⇒ If pieces of paper or other bulky objects are obstructing the front dust seal (FLAP) you can clear it by raising and lowering the flap several times, moving the flap lever n°2.

CLEANING THE FILTERS

- Effective operation of the sweeper depends on the state of the filters which must be kept clean.
- If the area to be cleaned is particularly dusty, filters must be shaken more often, at least every 5 minutes.
- ⇒ Move the lever n°3 to the C position for 5 seconds.
- ⇒ Repeat this operation a few times.

This automatic system for cleaning the filters is a "POWERBOSS, Inc." patent.

SAFETY DEVICES AND PARTS.

Warning ! The safety parts and devices must not be tampered with. They can be removed only when executing maintenance operations.

HOOD. The hood is a mobile part connected to the machines frame by mean of hinges. It prevents the access to moving parts. It is also an acoustic and thermic insulator. The machine can not be operated when the hood is raised.

HOOD SUPPORT The hood support is a mechanical safety device which prevents the hood from falling once it has been opened. It does not need any adjustment.

TOTAL STOP KEY SWITCH. The total stop key switch is an electric safety device. It cuts off all electric parts while the hood is open. To re-activate the machine, close the hood and insert the key into the switch.

PERIODIC MAINTENANCE.

CHECK	OPERATOR	AUTHORIZED SERVICE CENTER
Brush state.	EVERY 10 HRS.	*
Filters state.	EVERY 10 HRS.	*
Main brush pressure	EVERY 50 HRS	*
Brake adjustment	EVERY 100 HRS	*
Advancer adjustment	EVERY 100 HRS	*
Belts tension.	*	EVERY 200 HRS
REPLACE		
Filters.	EVERY 300 HRS	*
Flaps	*	EVERY 300 HRS
Brushes	*	WHEN WORN OUT

IMPORTANT RULES TO BE FOLLOWED WHEN SERVICING THE MACHINES.

Before servicing the machine, disconnect the machine from its power source:

- ⇒ 37 G: Disconnect the spark plug and the starting battery clamp.
- ⇒ 37 E: Disconnect the connector (n°1 pic.7).

ADJUSTING THE BRAKE

- ⇒ Adjust the screw (n°5 PIC.4).

REPLACING THE FILTERS

- ⇒ Shake the filters (n°4 PIC.6) thoroughly.
- ⇒ Remove the filter holder/cover (n°3 PIC.6).
- ⇒ Change the filters (n°4 PIC.6), making sure the seals are in the correct position, and the filter collar is correctly fitted inside the hole in the sweeper frame.
- ⇒ Put the filters holder/cover back on and tighten it down, checking that the filters are located in their seating.
- ⇒ Replace all the components removed, then tighten all screws.

ADJUSTING THE TRACTION

- ⇒ Adjust the screw (n°2 PIC.4).

MAIN BRUSH ADJUSTMENT

- ⇒ Loosen the screws (n°2 PIC.5).
- ⇒ Turn the nuts (n° 3 fig 5).

NB: These nuts must be adjusted all at the same level in order to maintain the main brush parallel to the floor .

- ⇒ Tighten screws (n°2 PIC.5).

CORRECT ADJUSTMENT CHECK-TEST

- ⇒ Stand the machine still.
- ⇒ Engage the main brush.
- ⇒ The clean path (PIC.8) left on the floor should be 70mm wide.

REPLACEMENT OF MAIN BRUSH

- ⇒ Remove the screws (n°4 PIC.5).
- ⇒ Remove the rubber flap holder (n°6 PIC.5).
- ⇒ Remove and replace the main brush.
- ⇒ Re-assembly the group.
- ⇒ Make the clean path test.

TROUBLESHOOTING GUIDE

MODEL COLLECTOR 37G

PROBLEM	CAUSE	SOLUTION
Battery flat.	1. Battery short-circuited. 2. Generator not charging.	1. Have it replaced. 2. Have it checked.
The engine won't start although the starter motor operates correctly.	3. Accelerator down. 4. Choke down. 5. Spark plug old or dirty. 6. Petrol filter clogged	3. Pull up to 1/3. 4. Pull up to maximum. 5. Replace it. 6. Replace it.
The engine won't start and the motor doesn't work.	7. Battery flat or faulty. 8. Starter motor faulty. 9. Contactor faulty. 10. Keyswitch faulty.	7. Recharge or have it replaced. 8. Have it replaced. 9. Have it replaced. 10. Have it replaced.
The engine smokes and is noisier than usual.	11. Carburettor out of adjustment.	11. Get the carburettor setting adjusted.

MODEL COLLECTOR 37E

Shaker doesn't work.	1. Vibrator motor faulty. 2. Fuse blown. 3. ON/OFF push-button faulty.	1. Have it replaced. 2. Have it replaced. 3. Have it replaced.
Battery won't charge.	4. Motors overloaded because of extraneous fragments or seized bearings causing friction between moving parts. 5. Electrolyte density too low.	4. Remove foreign or change seized bearings. 5. Recharge the battery, have it replaced if necessary.
Everything stays off when the key is inserted.	6. Battery flat or faulty. 7. Fuse blown.	6. Recharge or replaced it. 7. Have it replaced.

BOTH VERSIONS

Dust inside the engine cover.	1. Filters broken or worn out. 2. Seals not fitted under filters.	1. Replace it. 2. Fit the seals.
The main brush doesn't clean uniformly and leaves material on the floor.	3. Brush raised. 4. Brush worn out. 5. Not enough pressure on floor. 6. Material has accumulated around brush.	3. Lower it. 4. Adjust the lever or have it replaced. 5. Increasing the spring load. 6. Have it replaced.
The main brush doesn't turn.	7. Belt broken 8. Belt loose.	7. Have it replaced. 8. Check belt tensioner.
No suction when moving.	9. Suction off. 10. Filters clogged.	9. Switch it on. 10. Shaker or replace them.
Material and dust comes out of the front.	11. Flap seal worn or broken. 12. Flap stuck.	11. Have it replaced. 12. Have it replaced.

Warning! Any other type of service operation or test, with the exception of those shown in the engine's manual or the battery's manual, must be carried out by authorized personnel only.

WASTE MATERIAL.

For the dumping of waste material such as oil, plastic parts, batteries, packing boxes, please contact those facilities authorized for the dumping of special waste.

VIBRATIONS

The level of vibration to which the operator is subjected is below the maximum level allowed by the CE DIRECTORY for industrial machinery (CEE 89/392).

NOISE LEVEL

The level of noise has been measured at the level of the operator's ear and while the machine is working .

MODEL COLLECTOR 37G " BRIGGS & STRATTON " .

⇒ The maximum value read is 86 dB.

MODEL COLLECTOR 37G " HONDA " .

⇒ The maximum value read is 87 dB.

MODEL COLLECTOR 37E.

The maximum value read is 70 dB.



PowerBoss[®]
The Power of Clean

“The Power of Clean”

PowerBoss Is A Full Line Manufacturer Of Sweepers and Scrubbers For Industrial Facilities.

PowerBoss, Inc 175 Anderson Street P.O. Box 1227- Aberdeen North Carolina 28315

Phone: 800-982-7141 - Fax: 1-800-277-7141 Local: 910-944-2105 Fax: 910-944-7409 e-mail: techsupport@powerboss.com

A Member Of The Hako Group